

VereMERS™ Detection Kit Instructions for Use

For Research Use Only

REF

VMER-RA50



50



Store at -25°C to -15°C (frozen components)
Store at 15°C to 25°C (ambient components)



83 Science Park Drive #04-02
Singapore (118258)

Contents

Intended Use	Error! Bookmark not defined.
Summary and Explanation.....	2
Principle of the Procedure	3
Kit Content.....	4
Storage Condition.....	5
Materials Required but Not Provided	6
Warnings and Precautions.....	7
Additional Precautions when Handling RNA Samples	7
Quality Control.....	7
Workflow.....	8
Specimen Collection, Handling and Storage	9
Sample Preparation.....	9
Protocol	10
Important notes before starting.....	10
1. Prepare RT-PCR Reaction Mix.....	11
2. Load RT-PCR Reaction Mix into Chip	11
3. Seal Chip for RT-PCR	13
4. Run Chip (RT-PCR).....	15
5. Prepare Hybridization Mix	18
6. Load Hybridization Mix into Chip	18
7. Seal Chip for Hybridization	20
8. Run Chip (Hybridization)	23
9. Wash Chip.....	23
10. Detection	25
Assay Controls	30
Interpretation of Results.....	30
Troubleshooting Guide	31
Limitations of the Test.....	34
Disposal.....	35
Technical Assistance	35
Contact.....	35
Understanding the Symbols.....	36
Product Use Limitations, Warranty Disclaimer.....	37
Notice to Purchaser	38

Purpose

VereMERS™ Detection Kit is a multiplex RT-PCR/microarray-based research use only test. This test is not for use in diagnostic procedures. This nucleic acid-based test is intended for the qualitative detection of Middle East Respiratory Syndrome Corona virus (MERS-CoV). This test is for use in conjunction with the VerePLEX™ Biosystem.

Summary and Explanation

Middle East Respiratory Syndrome (MERS) is an illness caused by a virus called Middle East Respiratory Syndrome Coronavirus (MERS-CoV). MERS affects the respiratory system (lungs and breathing tubes), and most MERS patients will develop severe acute respiratory illness with symptoms of fever, cough and shortness of breath, with a death rate of 30%.

MERS was first identified in Saudi Arabia in September 2012, and through retrospective investigations, it was ascertained that the first known cases of MERS occurred in Jordan in April 2012. This virus is known to spread from ill people to others through close contact, though there is no evidence of sustained spreading in community settings. However, it is widely recognized that MERS-CoV has the potential to cause global outbreaks, and as such, the need for an accurate and reliable test for surveillance and detection is essential.

VereMERS™ Detection Kit uses the lab-on-Chip (LOC) platform for simultaneous and qualitative detection and identification of MERS-CoV based on selected target genes.

Principle of the Procedure

VereMERS™ Detection Kit includes a single-use disposable VereChip™ as well as reagents and consumables necessary for nucleic acid amplification and DNA hybridization. PCR primers and probes are designed to target the different genes of MERS-CoV as well as internal controls. This test is for use in conjunction with the VerePLEX™ Biosystem.

The VerePLEX™ Biosystem consists of the following components:

- Temperature Control System (TCS), which is a system that thermally drives the VereChip™. It consists of five Temperature Control Modules (TCMs) that allow five independent temperature programs to be run independently
- Optical Reader (OR), which detects and analyzes the microarray fluorescence in the range between 670 and 730 nm
- Touch Monitor (TOM), which connects to the TCS for display and input via touch
- Barcode Reader
- VerePLEX™ Biosystem Software

The system requires a VereChip™, on which a miniaturized reactor for PCR amplification, and a DNA microarray are integrated.

The DNA microarray consists of microscopic spots of DNA oligonucleotides called probes that are fixed on a silicon substrate. These probes are short sections of target genes which hybridizes to a complementary strand of amplified product. The amplified product is labeled with a fluorophore dye and probe-product hybridization is detected as a fluorescent signals and captured by CCD camera in the OR.

The probes for targets are spotted in duplicates in a 6 rows x 21 columns layout. If target pathogen is in the sample and captured, respective probes will light up in a particular pattern on the microarray. For a sample to be positive for a particular gene or pathogen, certain criteria must be satisfied. The criteria are written in “*Diagnostic Rule files*” provided in the BioApplication. The VerePLEX™ Biosystem Software relies on this set of rules for pattern interpretation.

Kit Content

Kit Catalog no.	VMER-RA50	
Tests	50	
Ambient Components (15°C to 25°C)	Part Number	Quantity
Box 1 of 3		
VereMERS™ Chip	MER-11	2 boxes
PCR Clamp	CPR-01	1 pack
IN Clamp	CIN-02	2 packs
HYB Clamp	CHY-01	1 pack
Wash Buffer Concentrate	VCP-WBC03	1 bottle
Frozen Components (-25°C to -15°C)	Part Number	Quantity
Box 2 of 3		
VereMERS™ Premix A	MER-PMX01	2 tubes
VCP Hyb Buffer	VCP-15B01	2 tubes
Hyb Probe Concentrate	VCP-HPC01	2 tubes
VeTaq™ One-Step Mix (2x)	VBI-OSM03/ VBI-OSM04	1 tube
RNase Inhibitor	VBI-RNI03/ VBI-RNI04	1 tube
Reverse Transcriptase	VBI-RTT03/ VBI-RTT04	1 tube
DEPC-treated Water	VBI-DWA03/ VBI-DWA04	1 tube

Storage Condition

- Store all Frozen Components at -25°C to -15°C upon receipt.
- Keep the Premix and Hyb Probe Concentrate away from light until ready to use.
- After initial thawing, Premix can be stored at 2°C to 8°C for up to 30 days. For longer storage, store at -25°C to -15°C.

NOTE: Repeated thawing and freezing may reduce the sensitivity of the assay.

- Keep RNase Inhibitor, Reverse Transcriptase and VeTaq™ One-Step Mix on ice block during usage, and store at -25°C to -15°C after use. These reagents are stable for up to 20 freeze-thaw cycles.
- Store reconstituted Microarray Hybridization Mix at -25°C to -15°C for up to 2 months. Keep the number of freeze-thaw cycles to <5 cycles..
- Store all Ambient Components at room temperature (15°C to 25°C).
- After opening the aluminum packaging, the Chips are stable for 2 months when stored in its original box at room temperature.

NOTE: Keep Chips away from light.

- Precipitation or crystallization may occur in Wash Buffer Concentrate if the storage temperature is low. Should this occur, please refer to important note before Chip washing step (page 23).
- Once opened, Wash Buffer Concentrate can be kept at room temperature for up to 1 year or until expiration date, whichever comes first.
- Store diluted Wash Buffer at room temperature for up to 2 months. Precipitation or crystallization may occur in diluted Wash Buffer if the storage temperature is low. Should this occur, please refer to important note before Chip washing step (page 24).
- If left unopened, all reagents are stable until the expiration date indicated on the respective labels.

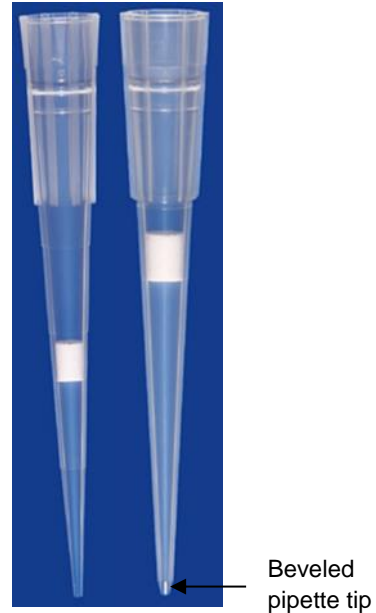
Materials Required but Not Provided

a) Reagents

- Qiagen QIAamp Viral RNA mini Kit¹ or equivalent
- PCR Grade Water
- Distilled/Reverse Osmosis (RO)/Ultrapure Water

b) Consumables

- Personal protective equipment
- Sterile beveled pipette tips² for Chip loading
- Sterile filter pipette tips
- 1.5 mL microcentrifuge tubes
- 0.2 mL PCR tubes
- Sterile 50 mL centrifuge tube (non-skirted)
- 1 L Bottle
- Decontamination products



c) Equipment

- Centrifuge with rotor and adapter for 50 mL centrifuge tube (non-skirted)
- Microcentrifuge for 1.5 mL tube
- Micropipettes (0.5-10 μ L, 2-20 μ L, 10-100 μ L, 100-1000 μ L)
- Freezer/Refrigerator (-20°C/4°C)
- Vortex Mixer
- Water Bath

d) Additional Accessories

- Ice or cooler unit
- Tube rack/stand
- Tweezers

¹ QIAGEN (Cat. No. 52904/52906)

² National Scientific Supply Company, Inc. (Cat. No. BUN020GL-MRS) is recommended

Warnings and Precautions

- All samples should be treated as potentially infectious.
- Wear appropriate personal protective equipment, including (but not limited to) protective disposable gloves, laboratory coats and eye protection when handling samples and kit reagents. Wash hands thoroughly after handling specimens and reagents.
- Clean and decontaminate work area and instruments, including pipettes, with commercially available decontamination products.
- A designated working area should be dedicated for processing specimens and to add extracted specimens to RT-PCR Reaction Mix.
- Use sterile pipette tips with filters.
- Handle Chip with care, avoid contact with the microreactor.
- Each Chip is used to process one test. Do not reuse processed Chips.
- Do not use kit, Chips or reagents after the expiration dates shown on the respective labels.
- Follow laboratory safety rules and procedures as defined by approved biohazard safety guidelines or regulations.
- Discard waste according to your local safety regulations.
- Material Safety Data Sheets (MSDS) are available upon request.

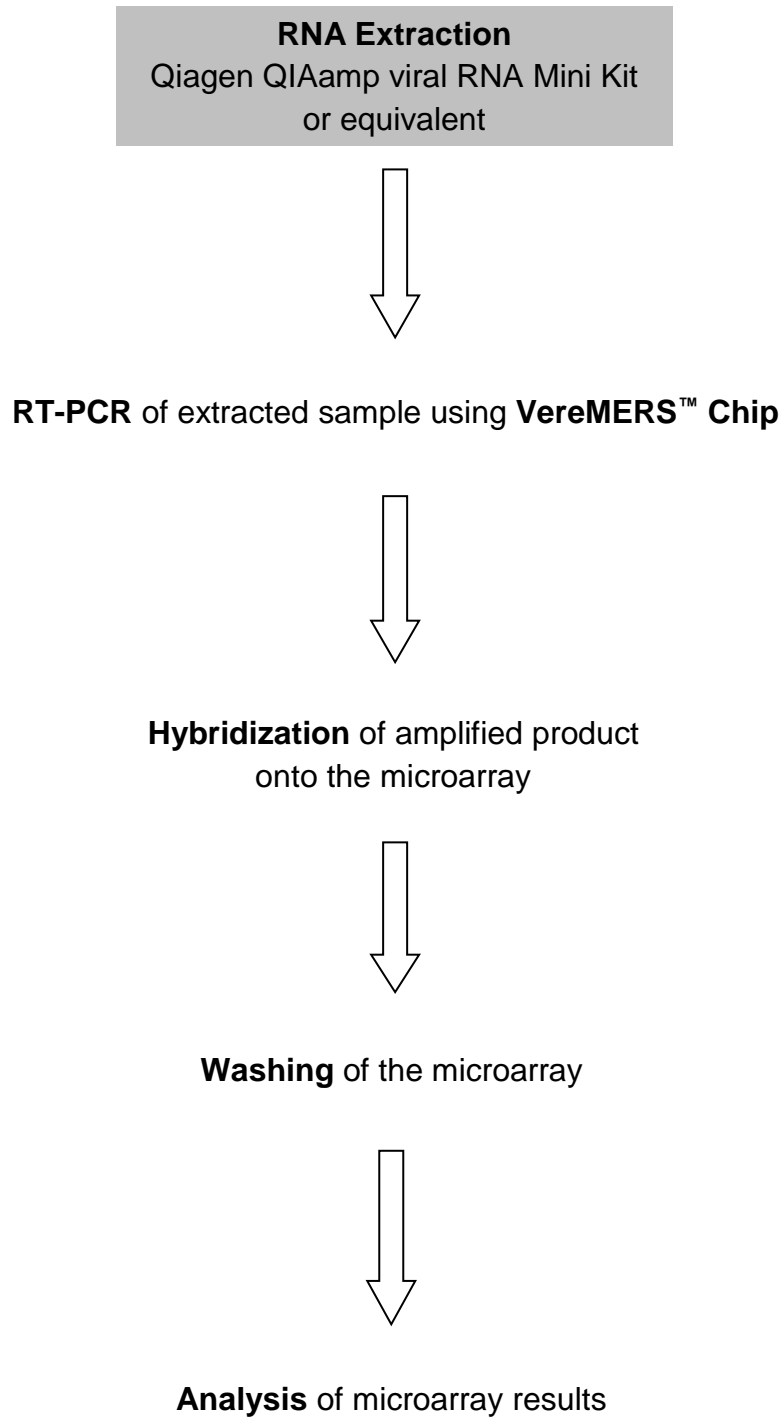
Additional Precautions when Handling RNA Samples

- Designate a separate working area for RNA work only.
- Clean work area and instruments, including pipettes, with 100% ethanol and/or commercially available RNase inactivation reagents.
- Always wear gloves while working with RNA. Avoid touching surfaces and equipment that are not decontaminated.
- Use only sterile and RNase-free disposable plastic ware.
- Use only nuclease-free water.
- Work quickly on ice.

Quality Control

Under Veredus' quality assurance program, the performance of our VereMERS™ Detection Kit is monitored routinely to ensure consistent product quality. Sampling is done on each lot and tests carried out via amplification of the respective control RNA fragment from *in vitro* transcription.

Workflow



Specimen Collection, Handling and Storage

Specimens should be collected, handled and stored following the user institution's standard procedures. Inadequate or inappropriate specimen collection, storage and transport are likely to yield false negative results. Training in specimen collection is highly recommended because of the importance of specimen quality.

Store extracted nucleic acids at 2°C to 8°C and use within 24 hours. For longer storage, store extracted nucleic acids at $\leq -70^{\circ}\text{C}$. Repeated thawing and freezing may affect the quality of the nucleic acid. They should be tested before use.

Sample Preparation

Extracted RNA is the starting material for the VereMERS™ Detection Kit. To obtain maximum performance, it is very important to establish the extraction process. Some naturally-occurring substances, such as heme, melanin, and polysaccharides could be PCR inhibitors and could interfere with the assay performance. Please refer to the respective manufacturer's handbook for detailed extraction procedure.

For sample elution, EDTA-containing buffer (TE, with 0.1-1.0 mM EDTA) is the standard in most of the extraction kit. However, EDTA in the sample may inhibit the PCR process if it is used at higher (i.e. 10 mM) concentration. Please check the extraction kit components for EDTA concentration.

The following nucleic acid extraction kit is recommended:

- Qiagen QIAamp Viral RNA Mini Kit³

³ QIAGEN (Cat. No. 52904/52906)

Protocol

Important notes before starting

- Thaw all frozen components thoroughly on ice before use.
- After thawing, briefly mix and centrifuge the components.
- Vortex briefly or pipette up and down 5-6 times when mixing reagents with enzymes. Avoid making bubbles.
- Precipitation or crystallization may occur in Wash Buffer Concentrate if the storage temperature is low. Should this occur, please refer to important note before Chip washing step (page 23).
- User intervention is required:
 - After the PCR protocol is completed, user to load hybridization mix into the Chip and return Chip to the TCM for hybridization step.
 - After hybridization protocol is completed, user to wash the Chip and place the Chip into the OR for detection.
- Use current VereMERS™ Chip version as follows:
 - MER-11
- For software, use current version or higher as follows:
 - VerePLEX™ Biosystem Version 5.3.X⁴
 - BioApplication VereMERS_1.1.1
- Screenshots are for illustration purposes only, and individual installations may vary.

⁴ Current VerePLEX™ Biosystem version. Subject to minor changes.

1. Prepare RT-PCR Reaction Mix

- i) Depending on the number of samples, prepare the required volume of RT-PCR Reaction Mix in a sterile PCR tube according to the following pipetting scheme:

Number of Reactions	1 reaction
PCR Reaction Mix Components	Volume (µL)
DEPC-treated Water	4.75
VeTaq™ One-Step Mix	12.5
VereMERS™ Premix	2
RNase Inhibitor	0.5
Reverse Transcriptase	0.25
Extracted Sample	5
Total	25

- ii) Mix thoroughly by pipetting or brief vortexing.
- iii) Briefly centrifuge to pull contents down to bottom of tube.

2. Load RT-PCR Reaction Mix into Chip

- i) Insert a VereMERS™ Chip into the Chip Holder and ensure a secure hold.

NOTE: To ensure a secure and firm positioning of the Chip, the holder has a pin fastener, press to release holder (*Figure 1*) when inserting and removing the Chip.



Figure 1: *Chip Holder*

- ii) Draw **11.5 μL** of the RT-PCR Reaction Mix with a pipette.

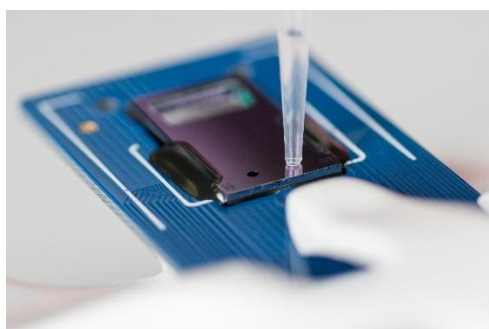
NOTE: Use a **20 μL pipette and recommended pipette tips⁵** for Chip loading.

- iii) Hold the pipette in a vertical position, in such a way that the tip is perpendicular to the surface.
- iv) Fit the tip into one of the inlet holes (see *Figure 2a*).
- v) Applying slight pressure onto the tip, press the plunger smoothly to the first stop position (see *Figure 2b*), allowing the mix to flow into the PCR chamber.



Do not press the plunger beyond the first stop as this will introduce air into the chamber and mix will flow into the microarray chamber. Keep the plunger at the first stop until you remove the tip from the inlet (this procedure avoids spilling and the injection of air inside the chambers).

- vi) Using a new pipette tip, repeat steps (ii) to (v) for another chamber. Load the Reaction Mix into the other inlet.



(a)



(b)

Figure 2: (a) Tip placement into an inlet hole during sample loading; (b) Pipette sketch indicating the different stop positions



Press and release the pipette plunger slowly at all the times. Never allow the push button to snap back. Check for foreign particles in the tip. Hold the pipette in an upright position while aspirating liquid.

⁵ National Scientific Supply Company, Inc. (Cat. No. BUN020GL-MRS) is recommended

3. Seal Chip for RT-PCR

- i) The IN and PCR sealing clamps are shown in *Figure 3*. The IN clamp (labeled “2 IN”) is dedicated to seal the inlet holes, and the PCR clamp (labeled “1PCR”) to seal the outlet holes in the microarray chamber.



Figure 3: IN and PCR clamps

- ii) The clamp undersides are different, owing to their specific sealing function:
- The “2 IN” clamp (*Figure 4a*) has an elastomer with a rectangular protrusion that seals the inlet holes, and one alignment pin that fits the corresponding hole on the Chip (*Figure 5*);
 - The “1PCR” clamp (*Figure 4b*) has an elastomer with a rectangular protrusion that seals the outlet holes, and two alignment pins that fit the corresponding holes on the Chip (*Figure 5*).

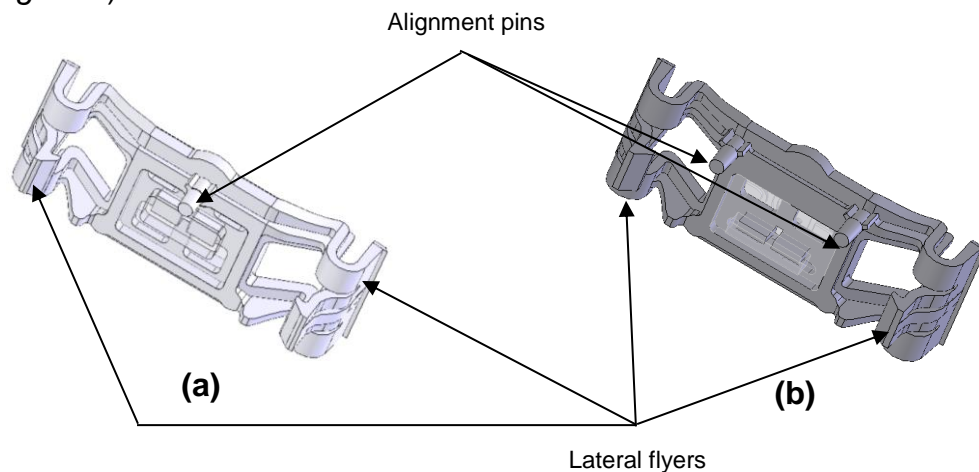


Figure 4: Bottom view of (a) “2 IN” and (b) “1PCR” clamps

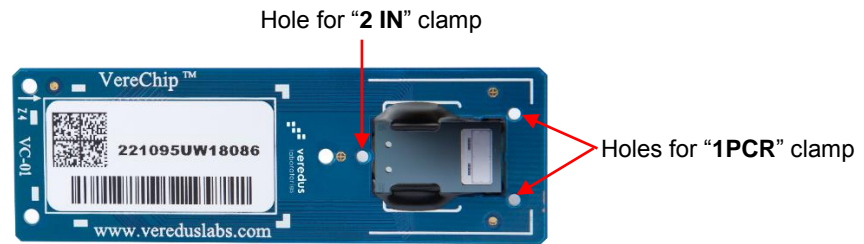


Figure 5: Alignment holes for “2 IN” and “1PCR” (or Hybridization) clamps

- iii) Attach the “1PCR” first by pressing the lateral flyers and placing the pins into the alignment holes (*Figure 4* and *Figure 5*). After reaching the final position (the solid part of the clamp touches the edge of the Chip) release the flyers and press the upper part of the clamp until a ‘click’ sound is heard (*Figure 6*).




Figure 6: “1PCR” clamp attached to Chip


- iv) Repeat step (iii) with “2 IN” clamp.
- v) After the Chip is sealed (*Figure 7*), remove Chip from the Chip Holder.



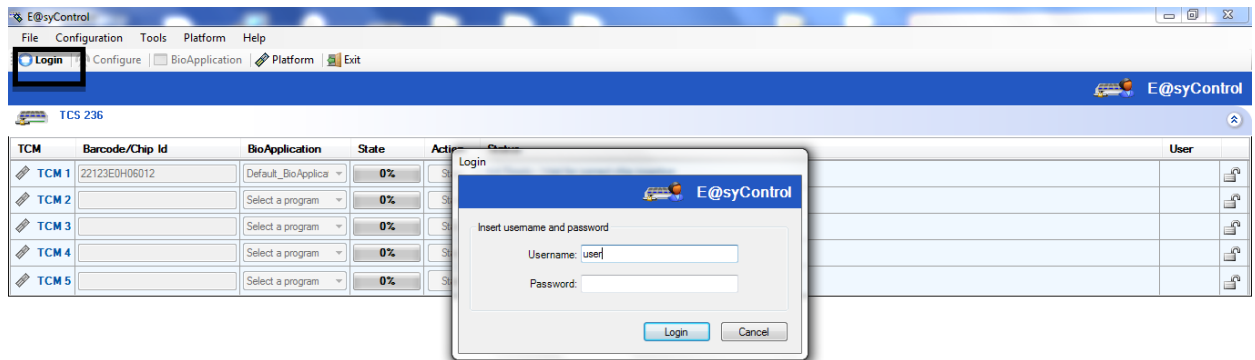
Figure 7: Sealed Chip ready for RT-PCR

4. Run Chip (RT-PCR)

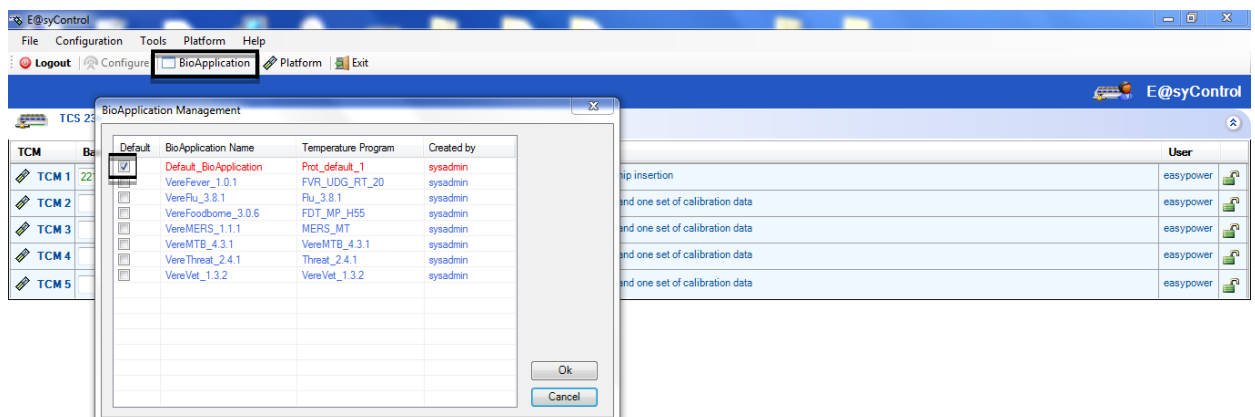
- i) Switch on the TCS.
- ii) Switch on the computer and launch “E@syControl” software by clicking on the icon  on the computer desktop.

The program will start searching for connected TCSs and the green TCS icon  will be displayed in the “E@syControl” window when TCS is connected. TCM will display “READY TO USE” message on the LCD screen.

- iii) Click “Login” on the toolbar. The “Login” window will be displayed. Log in with the correct username and password.



- iv) Select “BioApplication” from the toolbar and check the “VereMERS” (version 1.1.1 or higher) BioApplication.



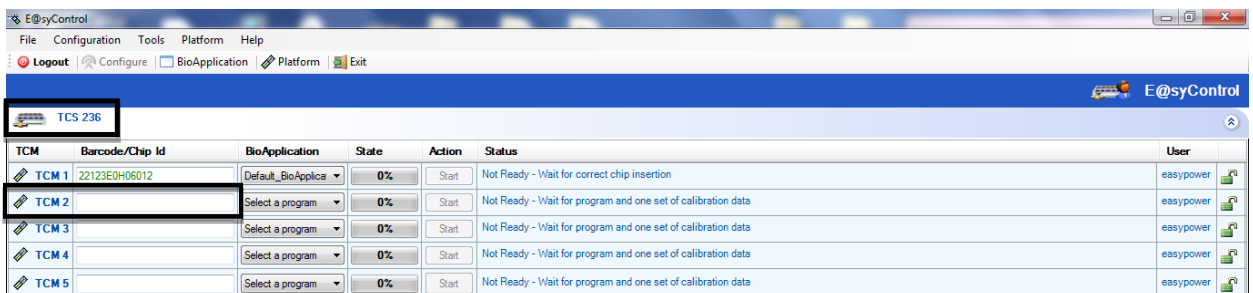
- v) Open the lid of the TCM (if not already open).
- vi) Place Chip into TCM.

NOTE: Ensure the alignment pins on the TCM are inserted into the corresponding alignment holes on the Chip (*Figure 8*).



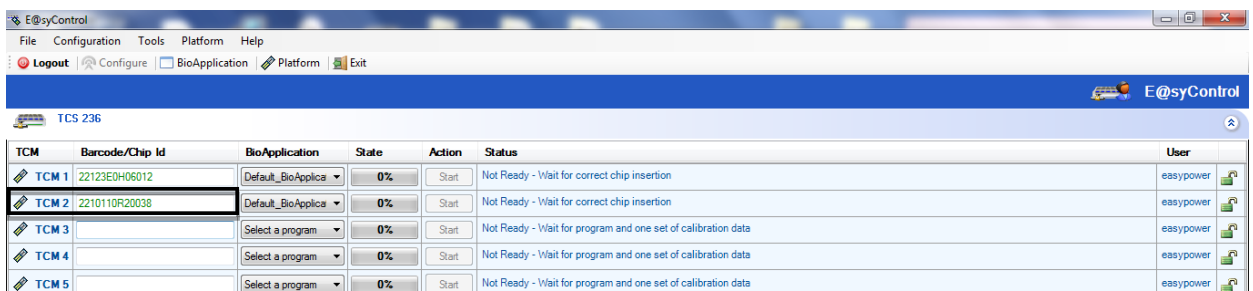
Figure 8: Chip inserted into the TCM

- vii) In the “E@syControl” window, select the appropriate TCS and place the cursor in the “Barcode/Chip Id” field of the respective TCM.



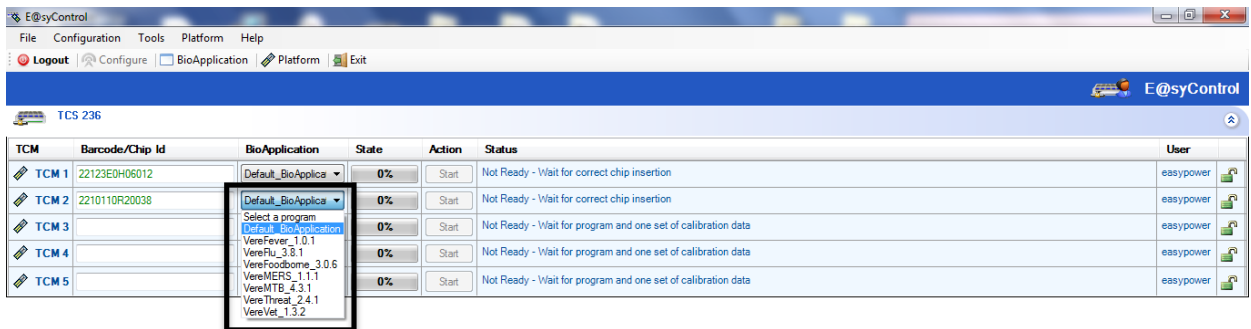
- viii) Scan the 2-D barcode on the Chip using the barcode scanner.

NOTE: Wait for the program to register the Chip calibration data before scanning the next Chip. The Chip ID should become “green” color.

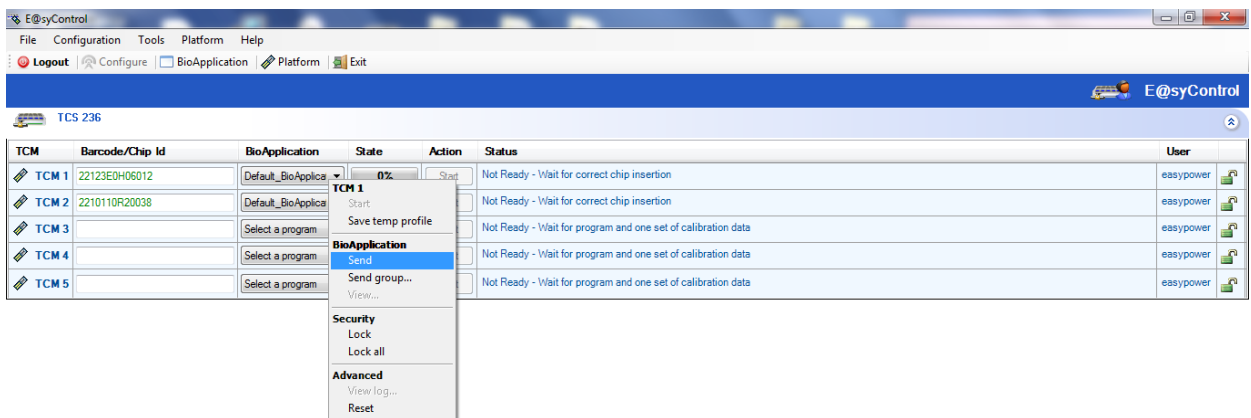


- ix) Repeat step (v) to (viii) to register all of the Chips to be run.

- x) For random access, select the relevant BioApplication from the dropdown list under “BioApplication” for each TCM.



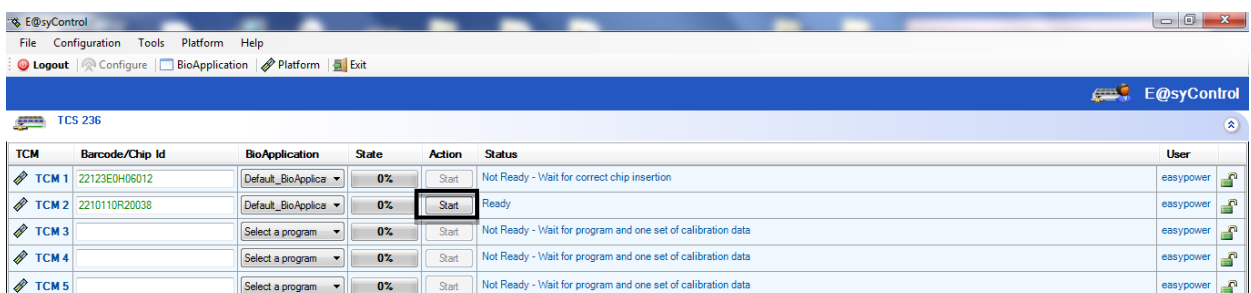
- xi) After selection, right-click the selected BioApplication. An option menu will be displayed. Select “Send” to load the selected program to the corresponding TCM.



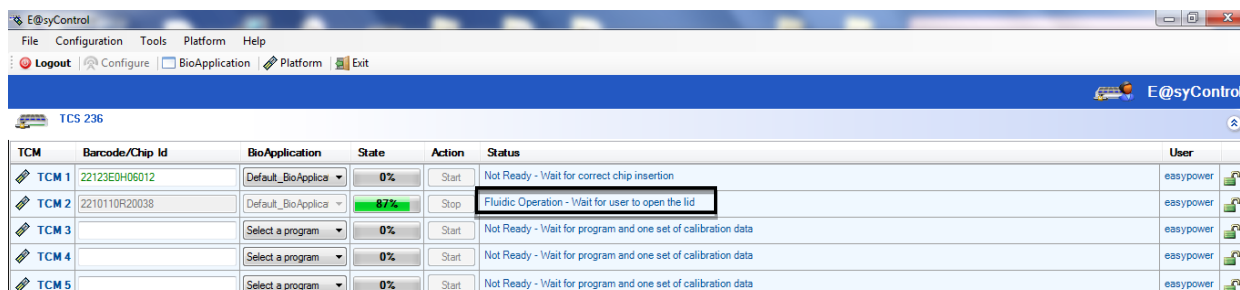
- xii) Close the lid of TCM. The TCM will validate the Chip against its calibration data and the TCM will display “CHIP VALIDATION” message on LCD screen.

- xiii) Once the Chip is validated, the TCM will display “CHIP INSIDE PRESS START” on the LCD screen or “Ready” in the “Status” field in the “E@syControl” window.

- xiv) Press “Play” button (▶) on the TCM front panel or click “Start” in the “E@syControl” window to begin thermal program.



- xv) Once the PCR protocol is completed, “*WAITING FLUIDIC OPERATION*” will be displayed on the LCD screen of the TCM or “*Fluidic Operation – Wait for user to open the lid*” will be displayed under the “*Status*” field in the “*E@syControl*” window.



5. Prepare Hybridization Mix

- i) Prepare Microarray Hybridization Mix by transferring **870 µL** of VCP Hyb Buffer to 1 tube of **30 µL** Hyb Probe Concentrate:

Number of Reactions	25 reactions
Hyb Mix Components	Volume (µL)
VCP Hyb Buffer	870
Hyb Probe Concentrate	30
Total	900

- ii) Leave Microarray Hybridization Mix at room temperature to equilibrate for at least 20 minutes.



Microarray Hybridization Mix must be equilibrated at room temperature for 20 mins before use. Mix well before use.

- iii) Mix thoroughly by vortexing the tube briefly (~10 seconds) or inverting it 4-6 times before spinning down.

6. Load Hybridization Mix into Chip

- i) Remove Chip from the TCM when prompted.
- ii) Insert Chip onto the Chip Holder and ensure a secure fit.
- iii) Remove “**2 IN**” and “**1PCR**” clamps and discard them. **DO NOT** reuse the clamps.

- iv) Draw **14.5 μL** of the Microarray Hybridization Mix with a pipette.

NOTE: Use a **20 μL pipette and recommended pipette tips⁶** for Chip loading.

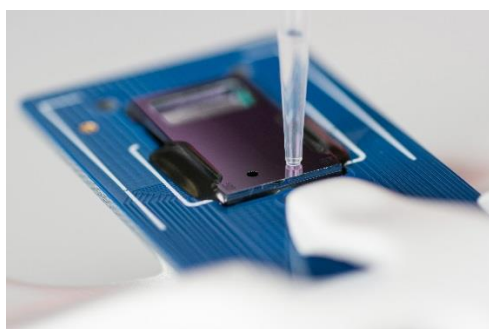
- v) Hold the pipette in a vertical position, in such a way that the tip is perpendicular to the surface.
- vi) Fit the tip into one of the inlet holes (see *Figure 9a*).
- vii) Applying slight pressure onto the tip, press the plunger smoothly to the first stop position (see *Figure 9b*), allowing the mix to flow into the PCR chamber. The PCR mix inside the PCR chamber will be displaced by the Microarray Hybridization Mix and will be observed to fill up the microarray chamber (*Figure 10*).



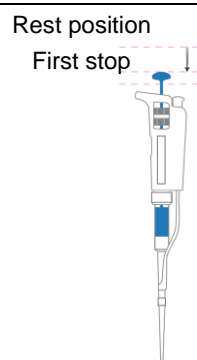
Do not press the plunger beyond the first stop as this will introduce air into the chamber and mix will flow into the microarray chamber. Keep the plunger at the first stop until you remove the tip from the inlet (this procedure avoids spilling and the injection of air inside the chambers).

- viii) Using a new pipette tip, repeat steps (vi) and (vii) for another chamber. Load the mixture into the other inlet.

NOTE: Use a new tip for every loading to prevent carryover of the PCR product.



(a)



(b)

Figure 9: (a) Tip placement into an inlet hole during sample loading; (b) Pipette sketch indicating the different stop positions



Press and release the pipette plunger slowly at all the times. Never allow the push button to snap back. Check for foreign particles in the tip. Hold the pipette in an upright position while aspirating liquid.

⁶ National Scientific Supply Company, Inc. (Cat. No. BUN020GL-MRS) is recommended

- ix) Tap the Chip gently at the side if the solution in the microarray chamber does not fully fill the microarray chamber.

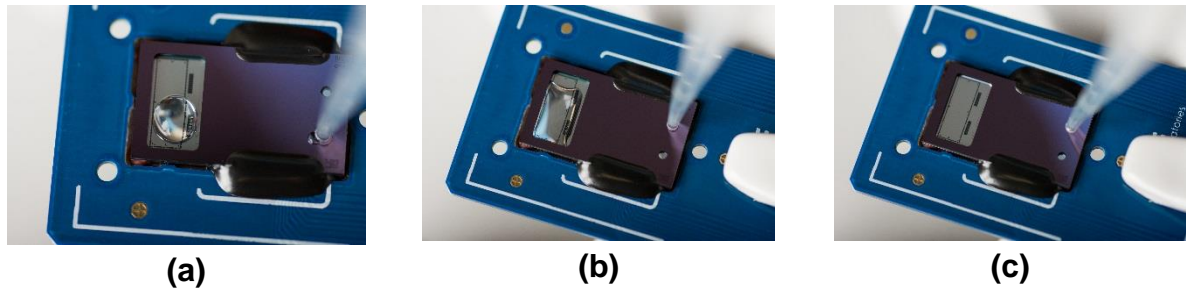


Figure 10: Microarray chamber filling – (a): filling of first inlet; (b) filling of second inlet (c): completely filled

7. Seal Chip for Hybridization

- i) Prepare a new IN clamp (labeled “2 IN”) and HYB clamp (not labeled) as shown in *Figure 11*.



Figure 11: IN and HYB clamps

- ii) The HYB clamp has a flat PDMS surface, 100 μm deep elicited in the gasket, and a surrounding trench used to accommodate the air displaced by the solution (*Figure 12*).

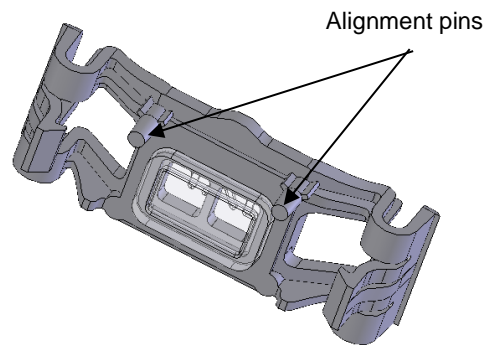


Figure 12: *Bottom view of HYB clamp*

- iii) Attach the “**2 IN**” clamp first (*Figure 13*).



Figure 13: “**2 IN**” clamp attached to Chip

- iv) Seal the microarray chamber carefully using the HYB clamp, making sure that no bubbles are introduced into the chamber (*Figure 14*).



Figure 14: Sealed Chip ready for the hybridization

NOTE: Should any bubbles form during the sealing of the microarray chamber, tap the Chip gently on the workbench, microarray closest to the bench surface. This will force the bubbles to migrate to the outlet edge of the PCR chamber where there are no probes (*Figure 15*).

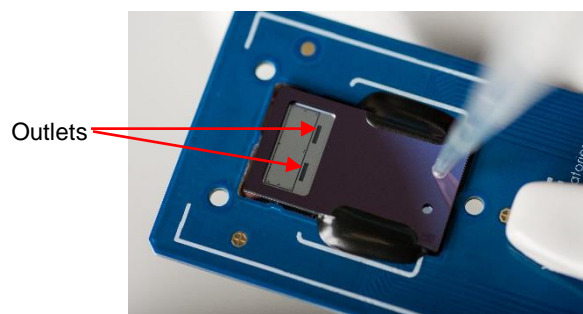
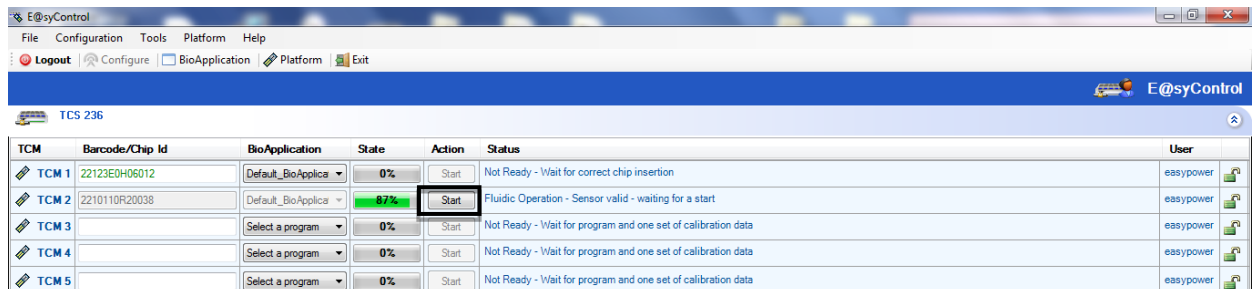


Figure 15: Outlet edge of the PCR chamber on the Chip

- v) Remove Chip from the Chip Holder, making sure the clamps are tightly held in place.

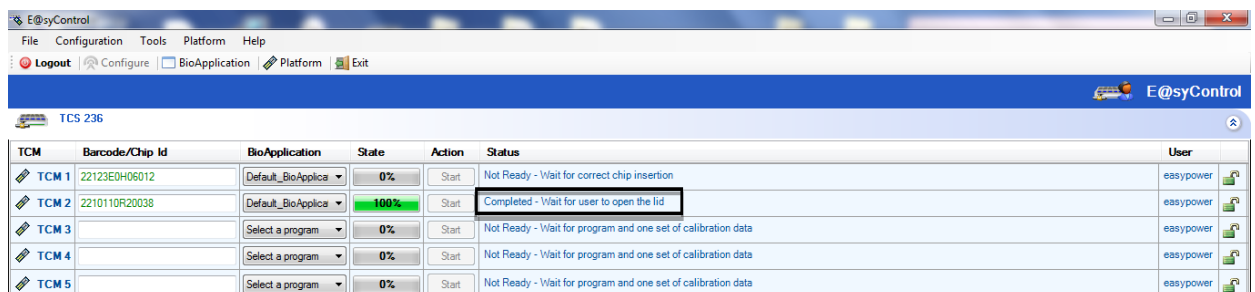
8. Run Chip (Hybridization)

- i) Load the sealed Chip into the respective TCM. Press “Play” button (▶) on the TCM front panel or press ‘Start’ when prompted.



TCM	Barcode/Chip Id	BioApplication	State	Action	Status	User
TCM 1	22123E0H06012	Default_BioApplica	0%	Start	Not Ready - Wait for correct chip insertion	essypower
TCM 2	2210110R20038	Default_BioApplica	87%	Start	Fluidic Operation - Sensor valid - waiting for a start	essypower
TCM 3		Select a program	0%	Start	Not Ready - Wait for program and one set of calibration data	essypower
TCM 4		Select a program	0%	Start	Not Ready - Wait for program and one set of calibration data	essypower
TCM 5		Select a program	0%	Start	Not Ready - Wait for program and one set of calibration data	essypower

- ii) Once the hybridization protocol is completed, “COMPLETED” message will appear on the LCD screen of the TCM or “Completed – Wait for user to open the lid” will be displayed in the “E@syControl” window. Remove the Chip from TCM and proceed to washing step (Section 9) immediately.



TCM	Barcode/Chip Id	BioApplication	State	Action	Status	User
TCM 1	22123E0H06012	Default_BioApplica	0%	Start	Not Ready - Wait for correct chip insertion	essypower
TCM 2	2210110R20038	Default_BioApplica	100%	Start	Completed - Wait for user to open the lid	essypower
TCM 3		Select a program	0%	Start	Not Ready - Wait for program and one set of calibration data	essypower
TCM 4		Select a program	0%	Start	Not Ready - Wait for program and one set of calibration data	essypower
TCM 5		Select a program	0%	Start	Not Ready - Wait for program and one set of calibration data	essypower



Temperature is one of the biggest factors to control hybridization process. TCM will not maintain the temperature after hybridization process is completed. To avoid exposure to the lower temperature, it is highly recommended to start washing step immediately after the hybridization protocol is completed.

9. Wash Chip



In case of precipitation or crystallization in the Wash Buffer Concentrate, warm up the entire bottle of buffer in a water bath set to 42°C for at least 1 hour with occasional shaking until all the precipitate is dissolved. Mix thoroughly before use.

- i) Measure 50 mL of the supplied Wash Buffer Concentrate into a 1 L empty bottle. Top up the 1 L bottle with Distilled/RO/Ultrapure Water to 1 L. Mix well.

Components	Volume (mL)
Wash Buffer Concentrate	50
Distilled/RO/Ultrapure Water	950
Total	1000

- ii) Prepare and fill non-skirted 50 mL centrifuge tubes with 50 mL of the prepared Wash Buffer from step (i) (*Figure 16*).



In case of precipitation or crystallization in the diluted Wash Buffer, warm up the entire bottle of buffer in a water bath set to 42°C with occasional shaking until all the precipitate is dissolved. Equilibrate at room temperature for at least an hour and mix thoroughly before use.

NOTE: Fill Wash Buffer to 50 mL mark on centrifuge tube to completely submerge the Chip. Place only ONE Chip per tube.

- iii) Remove the “2 IN” and HYB clamps, paying attention that no liquid spills out. Discard clamps. **DO NOT** reuse the clamps.
- iv) Insert Chip with the microarray end at the top into the centrifuge tube (*Figure 17*). Screw the tube cap on.



Figure 16



Figure 17



Figure 18

- v) Place the tube with the microarray side facing towards the rotor axis (*Figure 18*).

- vi) Centrifuge the tube at 3000 rpm for 2 minutes.



The centrifuge spins at high speeds. Ensure that the lid is closed properly and that all the buckets are correctly balanced.

- vii) After centrifugation, empty the tube of Wash Buffer and place tube back into the centrifuge with the microarray in the same orientation as step (v).
- viii) Centrifuge the tube at 3000 rpm for 2 minutes to spin-dry the microarray.
- ix) After centrifugation, remove the Chip using a pair of tweezers.
- x) Proceed to detection step immediately.



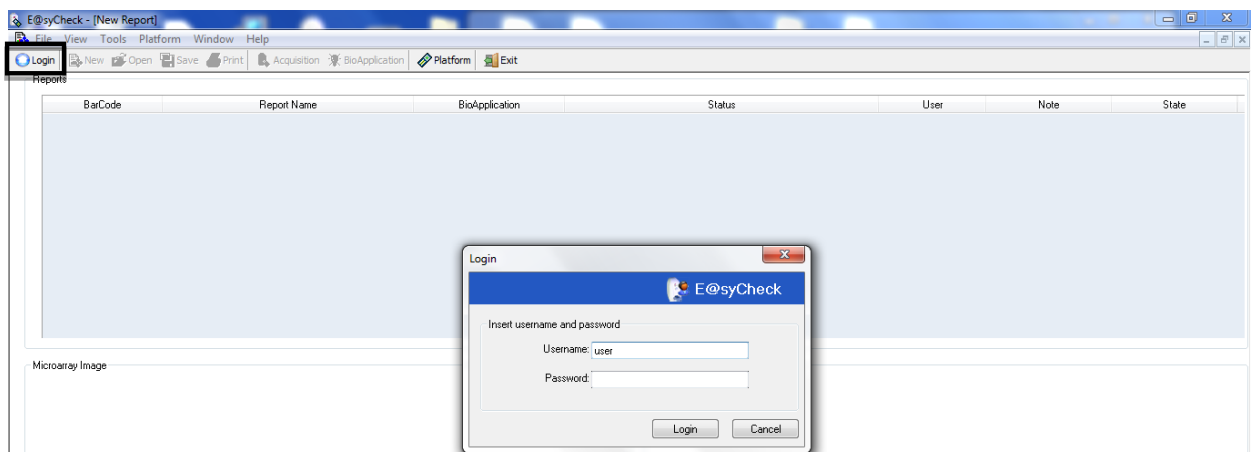
Fluorescent dye is used and is prone to degradation upon ozone exposure. It is highly recommended to proceed to the detection step immediately after washing. Minimize exposure of hybridized arrays to light, high temperatures and high ozone levels after washing. Place the Chip with the microarray face down on a clean paper towel or in a container.

10. Detection

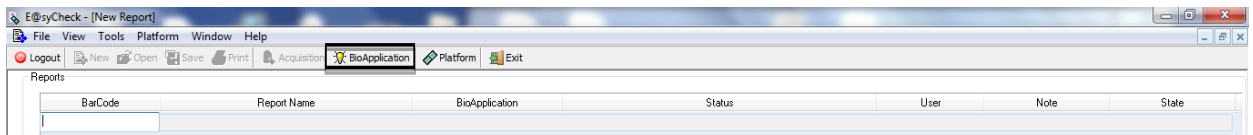
- i) Switch on the Optical Reader (OR).



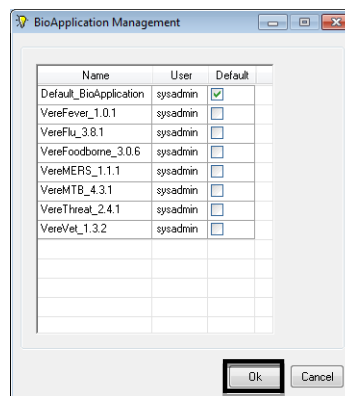
- ii) Launch “E@syCheck” software by clicking on the icon on the computer desktop.
- iii) Click “Login” on the toolbar. The “Login” window will be displayed. Log in with the correct username and password.



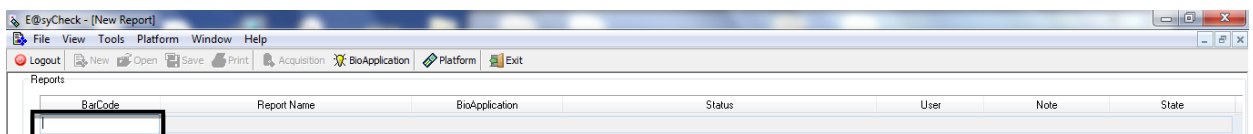
iv) Click “*BioApplications*” on the toolbar.



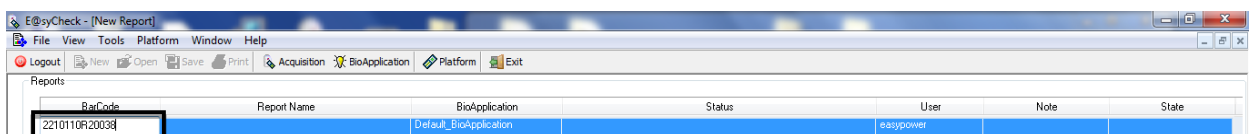
v) The “*BioApplication Management*” window will be displayed. Check the “**VereMERS**” (version 1.1.1 or higher) BioApplication. Click “OK” to proceed.



vi) Click on the “*Barcode*” field to bring the cursor to this location.



vii) Scan the 2-D barcode on the respective Chip.



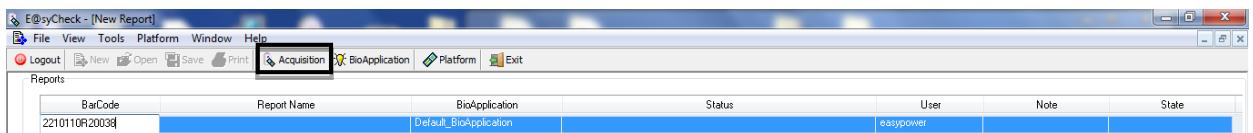
viii) Open the OR lid (if not already open).

- ix) Insert Chip into the OR with the microarray facing up (*Figure 19*).

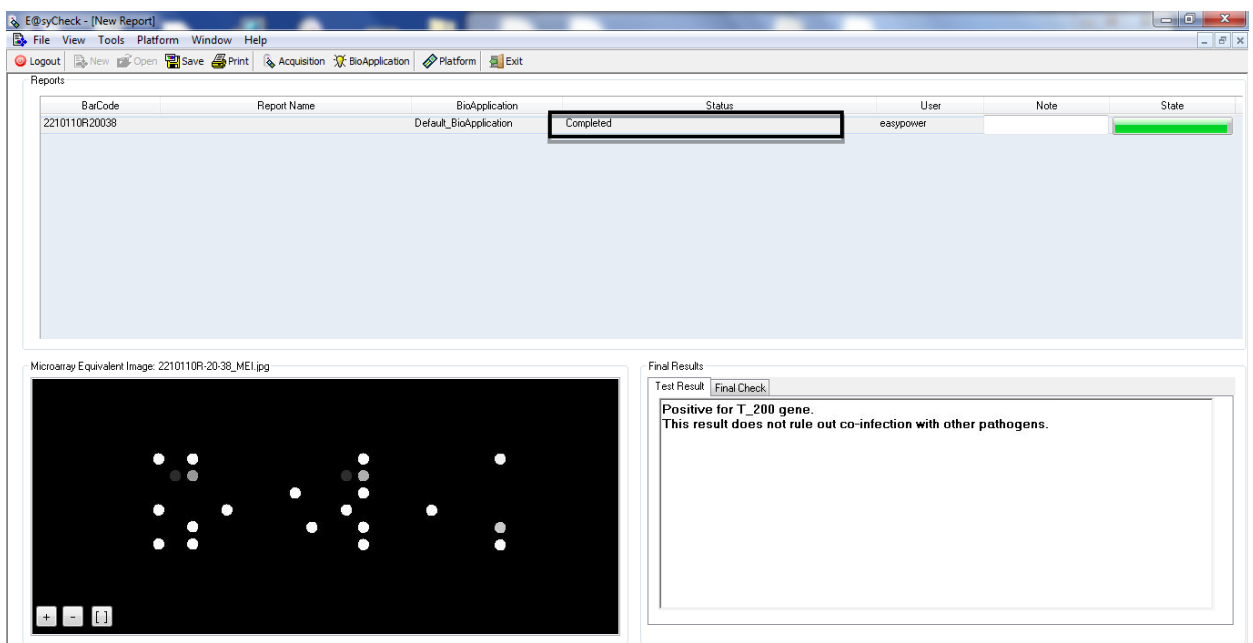


Figure 19: Chip inserted into OR

- x) Click on “Acquisition” button on the toolbar. The OR will begin image acquisition and image analysis immediately.



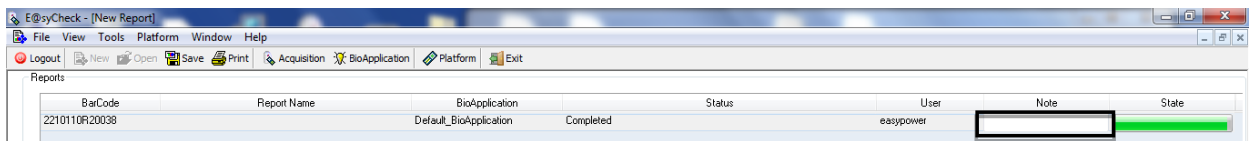
- xi) After “Acquisition” operation, “Completed” will be displayed in the “Status” field and the results will be displayed.



Clicking the “*Final Check*” tab shows target/control detection summary.

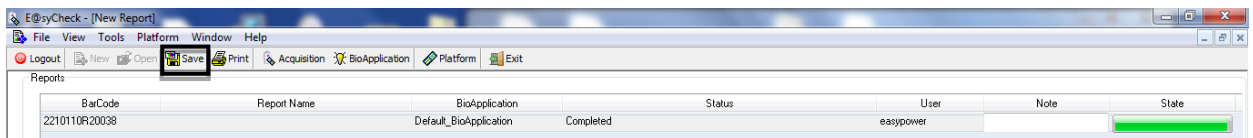
Target	Result
T_100	Not Detected
T_200	Detected
T_300	Not Detected
T_400	Not Detected
T_500	Not Detected
T_600	Not Detected
T_700	Not Detected
T_300 / T_400	Not Detected
T_800 / T_900	Not Detected

- xii) Comments on this particular Chip run can be recorded under the “*Note*” field and this will be printed on the final report.

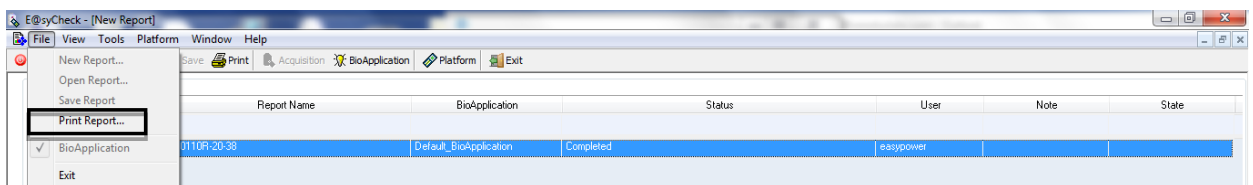


NOTE: “*Note*” field can be modified only **BEFORE** saving the analysis.

- xiii) To save the analysis, press “*Save*” button on the toolbar. All the information associated to the analysis will be stored in a local database.

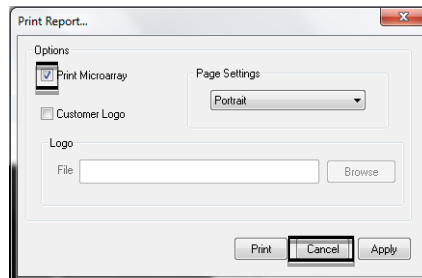


- xiv) Click “*File*” on the top toolbar and select “*Print Report*” from the context menu.

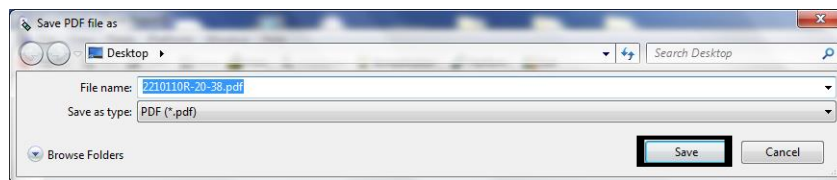


xv) The “*Print Report*” window will be displayed. Click “*Print*” to proceed.

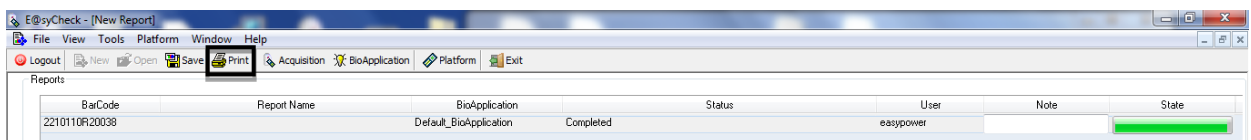
NOTE: By default, the microarray equivalent image is not included in the PDF report, check “*Print Microarray*” to print report with the microarray equivalent image.



xvi) A “*Save PDF file as*” window will be displayed. Save file in the desired destination folder. Click “*Save*” to proceed.



xvii) Alternatively, press “*Print*” button on the toolbar to display and print the PDF report.



Assay Controls

The following controls are included in each test:

1. Internal RT-PCR control to check for successful nucleic acid amplification reaction
2. Positive and negative hybridization controls to check for hybridization-related issues
3. Orientation control for microarray grid alignment

It is recommended to include a negative control sample for each test run to check for possible contamination.

Interpretation of Results

The VerePLEX™ Biosystem software provides a qualitative result for the presence (Detected) or absence (Not Detected) of the target gene/organism under the “*Test Result*” and “*Final Check*” tab on the software interface and the final printed report. “Inconclusive” will be displayed for presence of bad spot signal(s) and the number of bad spot fails to meet the set criteria.

The control fields will display “Valid”, “Not Valid” and “Inconclusive”. If the hybridization control and/or and negative control is “Not Valid” or “Inconclusive”, the software will not proceed with any further data analysis and the result of the control will only be displayed in the “*Test Result*” section. No result will be displayed in the “*Final Check*” section. The validity of PCR control has no influence of the outcome of the result if the target is “Detected”.

For further details regarding the interpretation of the results and recommended actions, please refer to Troubleshooting Guide or contact our Technical Support.

Troubleshooting Guide

The troubleshooting guide may be helpful in solving problems that may arise.

Comments and Recommended Actions	
Instrument and Software Issues	
1. Hardware failure	Make sure that the instruments (TCS and OR) are properly maintained. Refer to the Troubleshooting section of the VerePLEX™ Biosystem SYSTEM & SOFTWARE IFU.
2. Error message displayed on the screen	Refer to the Troubleshooting section of the VerePLEX™ Biosystem SYSTEM & SOFTWARE IFU.
No Results	
1. Negative control “Not Valid” OR “Inconclusive”	<ol style="list-style-type: none"> 1. Make sure the correct BioApplication is used. 2. One or more negative control probes have a fluorescent signal due to a high fluorescent background or fluorescent artifacts in the microarray surface. This problem may occur in the following situations: <ol style="list-style-type: none"> a. Dust or fiber-like material is found on the microarray area. Inspect the area and repeat detection step. If the high background persists repeat the test. b. The Chip is not washed properly. Repeat the washing step following carefully the Instructions for Use (IFU). If the high background persists repeat the test. c. The Wash Buffer is not diluted according to the instructions. Prepare a new bottle of Wash Buffer following carefully the IFU and repeat the washing step using the newly prepared Wash Buffer. If the high background persists repeat the test. d. The Hybridization clamps are not properly inserted causing partial or total evaporation of the Microarray Hybridization Mix with a consequent drying of the fluorescent mix on the microarray surface. Repeat the test. e. Contamination. Repeat the test. Ensure that the workspace and instruments are decontaminated at regular intervals. Refer to the Cleaning section of the respective IFU.
2. Hybridization control “Not valid” OR	<ol style="list-style-type: none"> 1. Make sure the correct BioApplication is used. 2. Some of the hybridization control probes are not lit up. This problem may occur when the labeled hybridization

Comments and Recommended Actions	
“Inconclusive”	<p>probes are partially degraded due to wrong storage conditions. Repeat the test using new reagents and follow carefully the IFU on Storage Condition.</p> <p>3. High fluorescent background or fluorescent artifacts in the microarray surface (see negative controls not valid or inconclusive comments and suggestions).</p>
3. No signal	<p>1. Make sure the correct BioApplication is used.</p> <p>2. Photo-bleaching of the dye signal in the microarray detection area due to high level of ozone in the lab. Repeat the test and minimize the microarray surface exposure to the light as much as possible.</p> <p>3. The labeled primers and hybridization probes are degraded due to wrong storage conditions. Repeat the test using new reagents and follow carefully the IFU on Storage Condition.</p> <p>4. The Wash Buffer is not diluted according to the instructions. Prepare a new bottle of Wash Buffer following carefully the IFU and repeat the washing step using the newly prepared Wash Buffer.</p> <p>5. Defective Chip. Repeat test with new Chip.</p> <p>6. The kit has expired. Check the expiry date of the kit and use a new kit, if necessary.</p>
PCR control “Not Valid”	
1. No fluorescent signals for PCR control probes but the specific target probes give signals	<p>1. Make sure the correct BioApplication is used.</p> <p>2. This may occur when the target nucleic acid is much more concentrated than the RT-PCR control. This has no influence on the outcome of the test.</p> <p>3. The RT-PCR control is degraded due to wrong storage conditions. This has no influence on the outcome of the test but use new reagents in the next run.</p>
2. No fluorescent signals for both the PCR control probes and the specific target probes	<p>1. Make sure the correct BioApplication is used.</p> <p>2. The RT-PCR control and the target nucleic acid are degraded due to wrong storage conditions. Repeat the test using new reagents and sample and follow carefully the IFU on Storage Condition.</p> <p>3. The RT-PCR control and the target nucleic acid are degraded due the presence of RNase. Check quality of nucleic acid sample or use fresh nucleic acid sample. Repeat the test and follow carefully the IFU on Warnings and Precautions and Additional Precautions on</p>

Comments and Recommended Actions	
	<p>Handling RNA Samples, particularly be careful not to introduce any RNases into the reagents during the mix preparation.</p> <ol style="list-style-type: none"> 4. The labeled primers are degraded due to wrong storage conditions. Repeat the test using new reagents and follow carefully the IFU on Storage Condition. 5. PCR was inhibited. Use recommended extraction kit. Refer to the manufacturer's handbook for detailed extraction procedure. Repeat the test. 6. Defective Chip. Repeat test with new Chip. 7. The kit has expired. Check the expiry date of the kit and use a new kit, if necessary.
Inconclusive results for specific probes	
1. One or more specific probes have bad spots	<p>Some of the spots of one or more specific probes are not recognized as a spot by the E@syCheck software. This problem may occur when the spot morphology is not good mainly due to a high fluorescent background or fluorescent artifacts on the microarray surface (see negative controls not valid or inconclusive comments and suggestions).</p>
2. One or more probes have one replica of a specific spots pair not lit up	<p>This problem may occur when there is not enough amplified dye-labeled target to hybridized the microarray due to the following reasons:</p> <ol style="list-style-type: none"> 1. The labeled primers are partially degraded due to wrong storage conditions. Repeat the test using new reagents and follow carefully the IFU on Storage Condition. 2. The target nucleic acid is partially degraded due the presence of RNase or poor sample preparation. Check quality of nucleic acid sample or use fresh nucleic acid sample. Repeat the test and follow carefully the IFU on Warnings and Precautions and Additional Precautions on Handling RNA Samples, particularly be careful not to introduce any RNases into the reagents during the mix preparation. Use recommended extraction kit. Refer to the manufacturer's handbook for detailed extraction procedure. Repeat the test. 3. Insufficient starting material. Repeat test with more increased amount of nucleic acid sample.

Limitations of the Test

- Use of this kit should be limited only to trained personnel.
- This test is a qualitative test and does not provide a quantitative value for the detected pathogen in the sample.
- Strict compliance with the IFU is required for optimal results. Modifications to these procedures may alter performance of the test.
- Appropriate specimen collection, handling, storage and processing procedures are required for the optimal performance of this test.
- This test is not to be used on specimen directly. Specimen needs to be processed using appropriate nucleic acid extraction methods prior to using this test.
- The dye used is susceptible to degradation upon exposure to ozone. Strict compliance with the processing procedures is required for optimal performance of the test. If possible, procedures should be done in a reduced ozone environment to eliminate degradation of the dye molecule.
- It is advised to scan each microarray only once, subsequent scans may not yield similar results as fluorescence intensity may decrease due to decay of the fluorophore.
- Results from the test should be interpreted with other laboratory data available.
- Although the kit is highly specific and sensitive, a low incidence of false results can occur. A negative result does not preclude the possibility of existence of the target organisms in the sample. Other available tests are required if questionable results are obtained.
- A specimen yielding a negative result may contain respiratory viruses other than MERS-CoV.
- Mutations within the target regions covered by primers and/or probes used in the test may result in failure to detect the target organisms.
- The prevalence of infection will affect the predictive value of the test.
- False negative results may occur due to presence of sequence variants in the viral targets of the assay, procedural errors, amplification inhibitors in specimens, or inadequate nucleic acids for amplification.
- False positive results may occur due to cross-contamination by target organisms, their nucleic acids, amplicons, or from non-specific signals in the test.
- Viral nucleic acids may persist *in vivo* independent of virus viability. Detection of analyte target(s) do not imply that the corresponding viruses are infectious.

Disposal

Dispose of hazardous or biologically contaminated materials according to local safety regulations.

Technical Assistance

If you have any questions or technical issues regarding the use of the kit, or any other Veredus products, please contact our technical support department.

Contact

Your opinions, comments, questions or feedback are important to us and all Veredus' customers. Please contact us if you have any suggestions about product performance or new applications and techniques.

For information and technical assistance, please contact us via:















Telephone: +65 6496 8600

Fax: +65 6779 2680

Email: info@vereduslabs.com

Visit our website: www.vereduslabs.com

Understanding the Symbols

Symbol	Meaning
	Catalog number
	Lot number
	Contains sufficient for <n> tests
	Do not re-use
	Date of manufacture
	Manufacturer
	Temperature limitation
	Use-by date (YYYY-MM-DD)
	Consult Instructions for Use
	Fragile, handle with care
	Keep away from sunlight
	Keep dry
	This side up
	Caution

Product Use Limitations, Warranty Disclaimer

Veredus Laboratories Private Limited (Veredus) manufactures products for a number of intended uses. Please refer to the product label for the intended use statements for specific products. Veredus products contain chemicals, which may be harmful if misused. Due care should be exercised with all Veredus products.

Veredus warrants that its products will meet the specifications stated on each product's specification sheet. If any component of the product does not conform to these specifications, Veredus will, at its sole discretion, as its sole and exclusive liability and as the users' sole and exclusive remedy, replace the product free of charge.

THIS WARRANTY LIMITS VEREDUS' LIABILITY TO THE REPLACEMENT OF THIS PRODUCT OR REFUND OF THE COST OF THE PRODUCT. NO OTHER WARRANTIES OF ANY KIND, EXPRESS OR IMPLIED, INCLUDING WITHOUT LIMITATION IMPLIED WARRANTY OF MERCHANTABILITY OR FITNESS FOR A PARTICULAR PURPOSE OR NON-INFRINGEMENT, ARE PROVIDED BY VEREDUS. VEREDUS SHALL HAVE NO LIABILITY FOR ANY DIRECT, INDIRECT, CONSEQUENTIAL OR INCIDENTAL DAMAGES ARISING OUT OF THE USE, THE RESULTS OF USE OR THE INABILITY TO USE THIS PRODUCT AND ITS COMPONENTS.

In no event shall Veredus be liable for claims for any other damages, whether direct, incidental, foreseeable, consequential, or special (including but not limited to loss of use, revenue or profit), whether based upon warranty, contract, tort (including negligence) or strict liability arising in connection with the sale or use or the failure of Veredus products to perform in accordance with the stated specifications.

Some components of nucleic acid analysis, such as specific methods and compositions for manipulating or visualizing nucleic acids for analysis, may be covered by one or more patents owned by other parties. Similarly, nucleic acids containing specific nucleotides sequences may be patented. Making, using, offering for sale, or selling such components or nucleic acids may require one or more licenses. Nothing in this document should be construed as an authorization or implied license to make, use or sell any so covered component or nucleic acid under any such patents.

Notice to Purchaser

The procedure outlined in this protocol contains proprietary information. By purchasing this product, the user is granted a limited license by Veredus Laboratories Pte Ltd to use this information as described. The user of this product agrees not to use any of these proprietary methods in any other application and agrees not to communicate (either orally or in writing) these proprietary methods to any other person or institution.

VereMERS™, VerePLEX™, VeTaq™ and VereChip™ are trademarks of Veredus Laboratories Pte Ltd (Singapore, SG)

All other names of products and brands stated in this IFU are trademarks or registered trademarks of their respective owners.

© 2018 Veredus Laboratories Pte Ltd. All Rights Reserved.